



Refractory Systems | **Iron and steel industry**



## Refractory systems for blast furnaces and pig iron transport

STEULER-KCH offers an extremely wide range of materials for lining blast furnaces depending on the specific installation conditions and loading. Highly wear-resistant and temperature change-resistant corundum brick pre-fired at up to 1700 °C withstands the mechanical stresses in the top of the blast furnace where the burden is introduced. The reduction zones below that use special shaped bricks made of fireclay and andalusite which provide outstanding reduction resistance.

The highest temperatures and the pressure of the column of burden subject the melting zone of the blast furnace to extremely high stresses. For this special high-stress application, STEULER-KCH supplies shaped brick annuli in chemically/ceramicly bonded andalusite grades. The bottom of the blast furnace, the hearth, is lined with multiple layers of carbon brick. In order to protect that material from the pig iron, STEULER-KCH provides low-iron, high temperature-resistant fireclay and andalusite grades for the „ceramic cup“ of the blast furnace along with high-refractory sintered mullite grades with outstanding corrosion resistance.

### Refractory systems for pig iron transport

Torpedo ladles must ensure safe transport of the pig iron from the blast furnace to the steelworks. For this application, STEULER-KCH offers fired andalusite and bauxite grades which withstand these complex conditions. In the high-stress impact area, and if necessary in the slag zone, resin-bonded brick types based on andalusite, bauxite or corundum are used in various grades which, depending on the requirements, may also contain SiC. The bonding and further carbon additives minimise the slag and pig iron wettability of the refractory lining, improve its resistance to temperature change and enhance its thermal flexibility. STEULER-KCH maintains a comprehensive range of shapes for lining different size ladles. This makes it possible to satisfy the lining requests of customers flexibly at all times.

In the back-up wall, the permanent lining, CO-resistant fireclay and andalusite grades withstand the conditions and ensure safe long-term operation.

Below: Schematic diagram of torpedo ladle lining

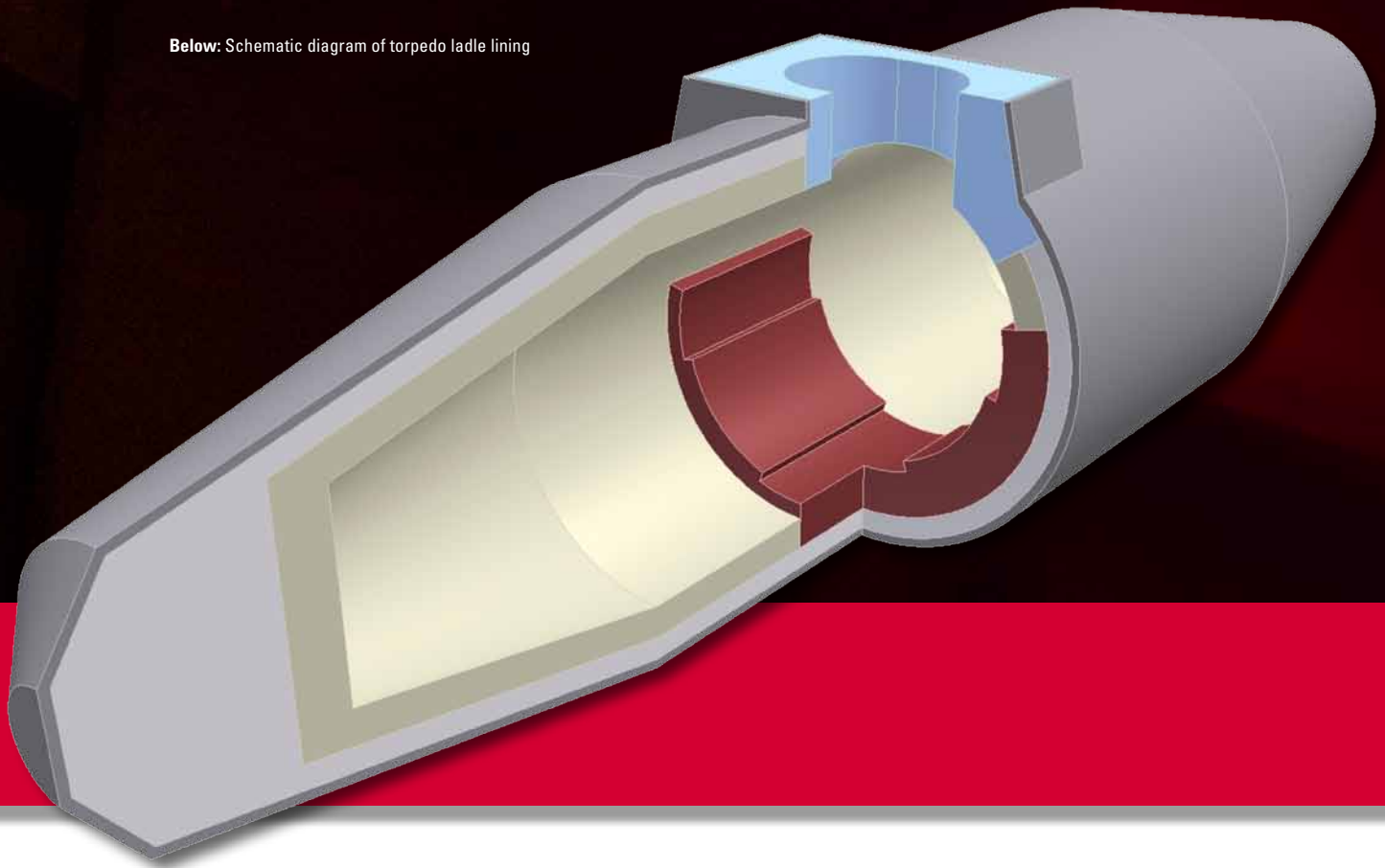

### Transfer ladles / hot metal ladles / teeming ladles

For the past several decades, STEULER-KCH has been providing back-up lining materials ranging from simple insulating fireclay brick to high-quality permanent lining with emergency operating properties. The wear lining and the bottom lining of the ladles are provided in the form of fired and resin-bonded AC and ASC brick. For special requirements, STEULER-KCH offers a broad spectrum of high-quality alumina products with a variety of additives such as SiC, chromium oxide and zirconium.



Above: Tuyere level



Above: Blast furnace bottom segment



## Innovative refractory concepts for direct reduction

For the direct reduction process, STEULER-KCH supplies individual solutions for all kinds of aggregates – ranging from air and process gas heaters to the reformer to the key component of the plant, the reduction furnace. There is an increasing demand for innovative refractory concepts to raise the efficiency of the plants. Now in addition to the high stresses already imposed on the refractory lining by the reducing atmosphere and temperature changes, material throughputs beyond the originally planned capacity also cause increased levels of abrasion.

### **Complete refractory concepts from a single source**

STEULER-KCH supplies a broad spectrum of lining materials not only for the shaft furnace, but also for reformers and recuperators. These include sealing and insulating concretes and lightweight refractory and insulating brick, along with calcium silicate, fibre blankets and anchoring systems. These lining materials are also used in gas and air heaters, piping and exhaust stacks.

Our extensive experience combined with the continuous further development of our products and services enables STEULER-KCH to offer individual refractory concepts for demanding applications.





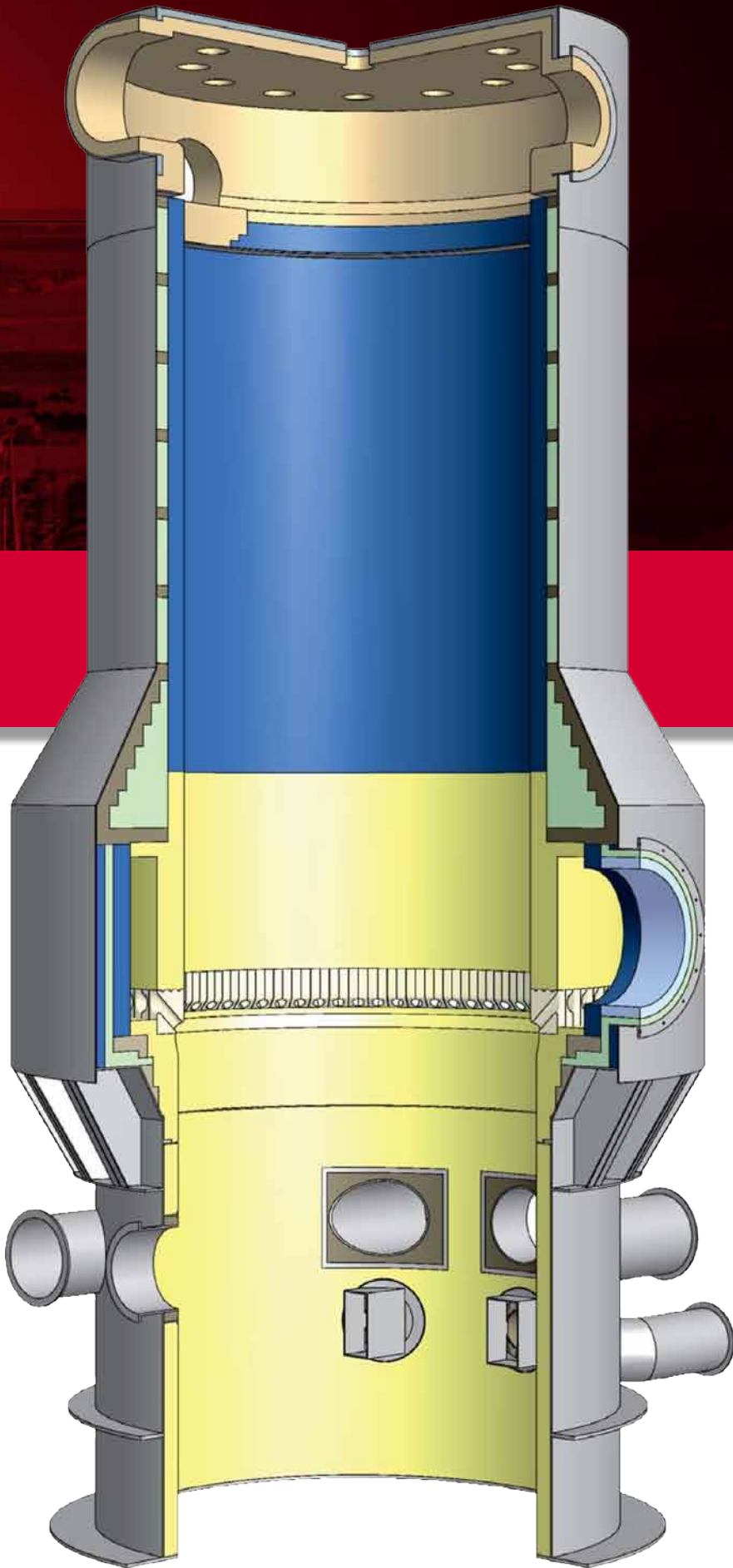

In the upper and lower section of the shaft, the lining must withstand severe abrasion caused by the iron ore and gas circulation. Due to these stresses we rely on highly abrasion-resistant brick and concretes which resist the reducing atmosphere and temperature changes at the same time. Here STEULER-KCH offers a combination of high-grade fireclay and phosphate-bonded high-alumina bricks which reliably withstand the required conditions.

### State-of-the-art brickwork lining concepts for Midrex® shaft furnaces

The gas inlet or „bustle area“ is certainly one of the most sensitive zones in the reduction shaft – and one of the most highly stressed ones as well. The refractory brick lining there is subject to extreme conditions, especially at the gas inlet nozzles. The brickwork lining must resist heavy wear, extreme temperature changes and the reducing gas.

STEULER-KCH has developed special materials for this application. Andalusite, corundum, fused mullite or zirconium-based materials are used here. These materials are capable of providing the required resistance to wear, temperature change and reduction by CO and H<sub>2</sub>.



## Refractory products for ingot casting

Modern ingot casting steelworks need extremely high quality refractory products to line the channels feeding their moulds. The steel blocks must be free of non-metallic inclusions and also have a consistent chemical composition and a homogenous structure.

With high quality, high alloy steels such as manganese steels, STEULER-KCH relies on the material B 80UG with a reaction-bonded mullite matrix and free  $\text{SiO}_2$  contents of less than 1.5%. The use of these refractory materials keeps the casting channels from widening and prevents alumina inclusions.

The special design of the tongue and groove joint generally eliminates the need to use mortar when laying the bricks, even in case of very high ferrostatic pressure.

Highly experienced in bottom-pour casting, the team from the development department and application engineering at STEULER-KCH is always available to provide assistance in the selection of refractory materials.

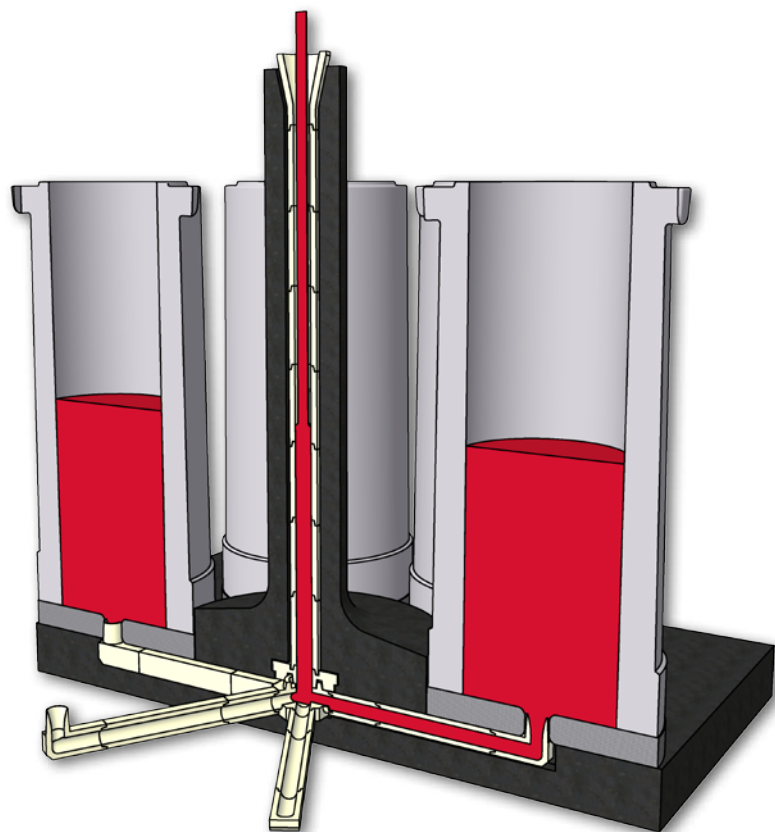



### Refractory materials for hydrochloric acid regeneration

In the steel pickling process, the iron-laden chemical cleaning solvent is regenerated either in spray roasting or fluidised bed plants. The objective is to regenerate the hydrochloric acid completely and return it to the pickling process. Iron oxide forms as a by-product, which can also be used as a raw material.

For both types of furnaces, Steuler supplies fireclay and andalusite grades and insulation materials along with the refractory engineering and installation – all from a single source.



Above: Upper section of a reactor with three-layer wall construction and monolithic ceiling mounted with anchors.



Above: Multilayer refractory lining comprising sheet metal protection, insulating bricks and refractory wear layer.





**Steuler Técnica S.L.**  
Spain

**Steuler France S.A.R.L.**  
France

**Ditescor S.A. de C.V.**  
Mexico

**Steuler Maroc S.A.R.L.**  
Marocco

**Alphaplast S.A.**  
Spain

**Steuler Nordic AB**  
Sweden

**Shanghai STEULER-KCH  
Anticorrosion Engineering  
Co. Ltd.**  
China

**CIMA S.r.l.**  
Italy

**KCT Sp. z o.o.**  
Poland

**Steuler Industrial  
Corrosion Protection  
Pty. Ltd.**  
Australia

**Steuler New Caledonia  
S.A.R.L.**  
New Caledonia

**STEULER-KCH**  
Branch Saudi Arabia

**STEULER-KCH**  
Branch Austria



Together with its international subsidiaries and representations, STEULER-KCH offers its customers a worldwide network which develops and implements comprehensive system solutions.



#### **SURFACE PROTECTION SYSTEMS**

Lining and flooring systems  
Cements, jointing materials, masonry systems,  
rubber linings



#### **PLASTICS TECHNOLOGY**

Thermoplastic lining systems  
Equipment, piping and tanks made of  
duroplastics and thermoplastics



#### **REFRACTORY SYSTEMS**

High temperature refractory linings



#### **POOL CONSTRUCTION**

STEULER-Q<sup>7</sup> lining systems



#### **STEULER-KCH GmbH**

##### **Refractory Systems Division**

Georg-Steuler-Straße  
56203 Höhr-Grenzhausen | GERMANY

Phone: +49 26 24 13-586  
Fax: +49 26 24 13-305  
Mail: [ff.info@steuler-kch.de](mailto:ff.info@steuler-kch.de)



Surface Protection Systems  
Plastics Technology  
Pool Constructions

Berggarten 1  
56427 Siershahn | GERMANY

Phone: +49 26 23 600-0  
Fax: +49 26 23 600-513  
Mail: [info@steuler-kch.de](mailto:info@steuler-kch.de)

[www.steuler-kch.de](http://www.steuler-kch.de)

**Focus on Progress**